

区分	精度	0.5	3	6	30	120	400	1000	2000
以下		3	6	30	120	400	1000	2000	4000
精度	穴加工	+0.1	+0.1	+0.2	+0.3	+0.5	+0.8	+1.2	+2.0
公差	面加工	+0.2	+0.3	+0.5	+0.8	+1.2	+2.0	+3.0	+4.0
公差	部品	+0.5	+1.0	+1.5	+2.5	+4.0	+6.0	+8.0	

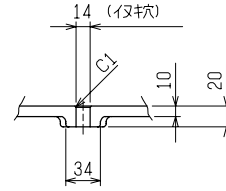

C-C 1/5

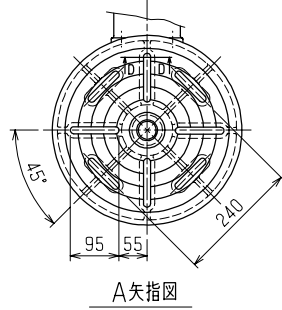
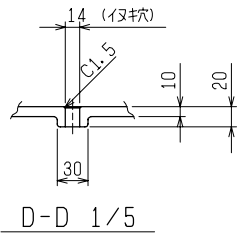
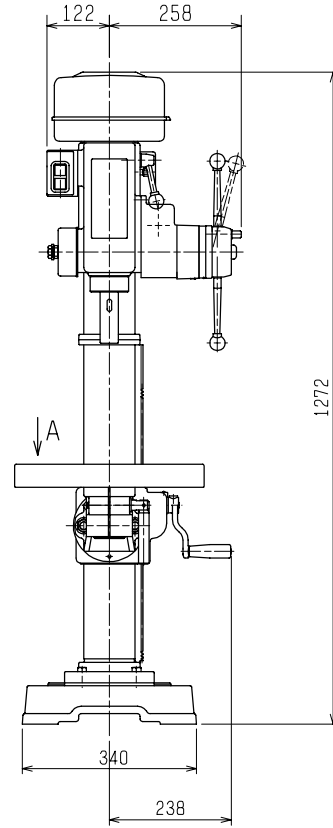
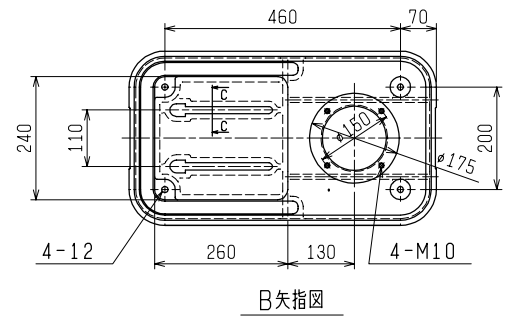
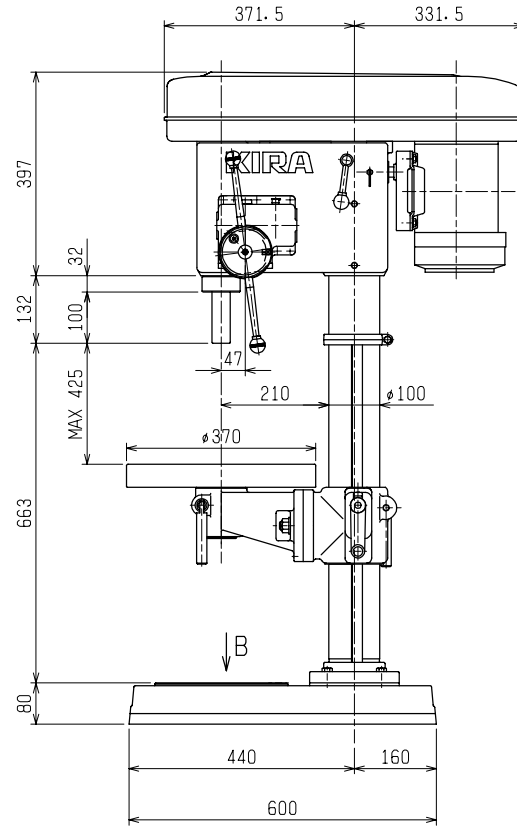

B矢指図

<table border="1"> <tr><td>△</td></tr> <tr><td>△</td></tr> <tr><td>△</td></tr> <tr><td>△</td></tr> </table>	△	△	△	△	<table border="1"> <tr><td> </td></tr> <tr><td> </td></tr> <tr><td> </td></tr> <tr><td> </td></tr> </table>					<table border="1"> <tr><td> </td></tr> <tr><td> </td></tr> <tr><td> </td></tr> <tr><td> </td></tr> </table>					<table border="1"> <tr><td> </td></tr> <tr><td> </td></tr> <tr><td> </td></tr> <tr><td> </td></tr> </table>					表面処理	出 図 年 月 日 照 査 設 計 製 図 型 式 TYPE KRDG-420P 品 名 外観図 (丸) NAME Machine dimension 品 番 DRAWING NO.	個数 QTY.
	△																					
	△																					
	△																					
△																						
熱処理	CHECKED	DESIGNED	DRAWN	96.2.24	材質 MATERIAL																	
焼入硬度	株式会社 キラ・コーポレーション KIRA CORPORATION			尺 度	1																	
符号	変 更 事 項	数 年 月 日 担 当 設 変 番 号	第三角法	SCALE	10																	