

区分	精度	0.5	3	6	30	120	400	1000	2000
以下		3	6	30	120	400	1000	2000	4000
公差	穴加工	+0.1	+0.2	+0.3	+0.5	+0.8	+1.2	+2.0	
公差	鍍金加工	+0.2	+0.3	+0.5	+0.8	+1.2	+2.0	+3.0	+4.0
公差	鋳造品	+0.5	+1.0	+1.5	+2.5	+4.0	+6.0	+8.0	

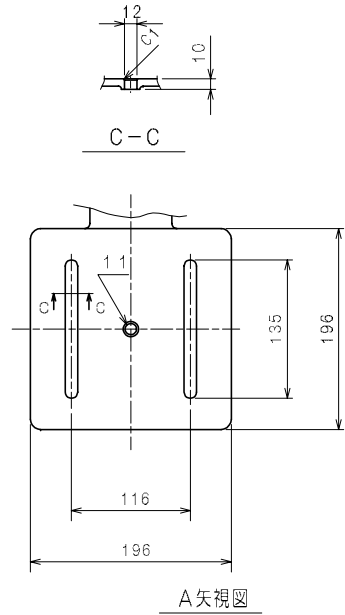

A矢视图

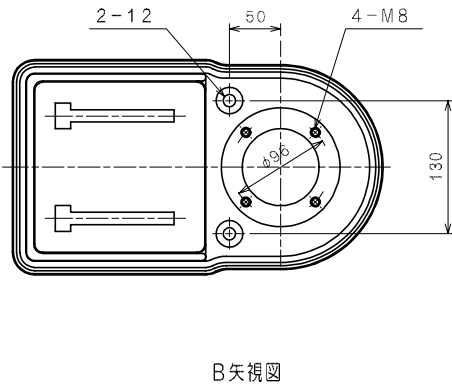

B矢视图

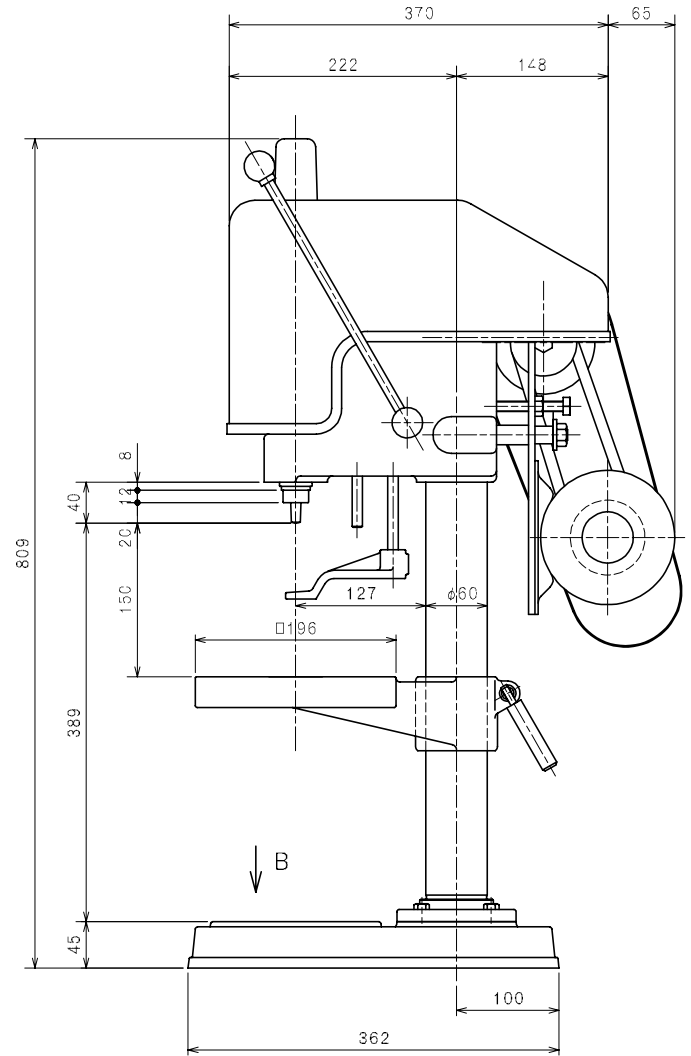
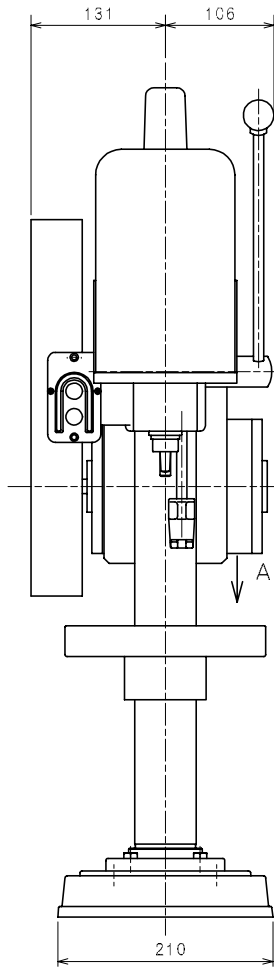

<table border="1"> <tr><td>△</td></tr> <tr><td>△</td></tr> <tr><td>△</td></tr> <tr><td>△</td></tr> <tr><td>△</td></tr> </table>	△	△	△	△	△	<table border="1"> <tr><td> </td></tr> <tr><td> </td></tr> <tr><td> </td></tr> <tr><td> </td></tr> </table>					<table border="1"> <tr><td> </td></tr> <tr><td> </td></tr> <tr><td> </td></tr> <tr><td> </td></tr> </table>					<table border="1"> <tr><td> </td></tr> <tr><td> </td></tr> <tr><td> </td></tr> <tr><td> </td></tr> </table>					表面処理	<table border="1"> <tr><td> </td></tr> <tr><td> </td></tr> <tr><td> </td></tr> <tr><td> </td></tr> </table>					照査	設計	製図	型式	<table border="1"> <tr><td>個数</td><td>QTY.</td></tr> <tr><td> </td><td> </td></tr> <tr><td> </td><td> </td></tr> <tr><td> </td><td> </td></tr> </table>	個数	QTY.						
	△																																						
	△																																						
	△																																						
△																																							
△																																							
個数	QTY.																																						
						CHECKED	DESIGNED	DRAWN	TYPE	KRT-10	材質	MATERIAL																											
								98.4.14	品名	外觀図																													
									NAME	Machine dimension																													
									品番	1C-0-0001	尺度	1/5																											
									DRAWING NO.		SCALE																												
符号	変更	事項	数	年月日	担当	設変	番号	第三角法	株式会社	キラ・コーポレーション																													
									KIRA CORPORATION																														